



DFC[®]250 EU MCFC-Fuel Cell Power Plant

250 kW; 400 V; 50 Hz

Key Features

Minimal environmental impact with almost “no NOx, no SOx”.

- ✓ High Efficiency
- ✓ Low Environmental Impact
- ✓ Fuel Flexibility
- ✓ High Reliability
- ✓ Quiet Operation

Advantages

DFC[®]250 EU - particularly suitable for applications in inner-city buildings.

The DFC[®]250 EU stationary fuel cell power plant from FuelCell Energy Solutions provides high-quality, Ultra-Clean electrical power with 47% efficiency around-the-clock. The system operates without vibration, has low emissions, is quiet, efficient and reliable. The operation is as simple as the planning and authorization.

The fuel cell power plant is suitable for use in commercial and industrial areas. DFC[®]-systems are ideal for sewage, industrial and business parks, food and beverage industry, universities and colleges, as well as utilities.

Power Output

Power at Plant Rating	250 kW
Standard Output AC Voltage	400 V
Standard Frequency	50 Hz
Optional Output AC Voltages	By Request
Optional Output Frequency	60 Hz

Efficiency

LHV	47 +/- 2%
-----	-----------

Available Heat

Exhaust Temperature	400 - 450 °C
Exhaust Flow	1.250 Nm ³ /h
Allowable Backpressure	15 mbar
Heat Energy Available for Recovery	150 kW (to 120 °C) 220 kW (to 50 °C)

Fuel Consumption

Natural gas (at 9,63 kW/m ³)	55 Nm ³ /h
--	-----------------------

Water Consumption

Average	0,18 m ³ /h
---------	------------------------

Water Discharge

Average	0,1 m ³ /h
Peak during WTS backflush	0,25 m ³ /h



FuelCell Energy Solutions
Ultra-Clean, Efficient, Reliable Power

Layout

The size is optimized to integrate the DFC®250 EU into the building.

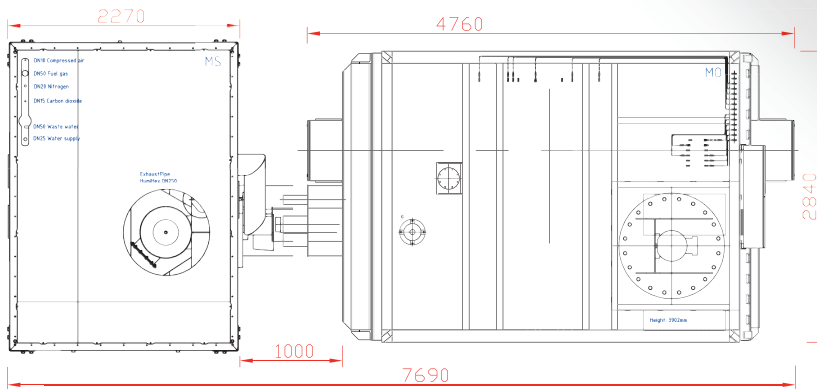

Dimensions

Fuel Cell Module and	total length: 7,69 m
Mechanical	wideness: 3,06 m
Balance of Plant	height: 3,90 m
Electrical	total length: 4,90 m
Balance of Plant	wideness: 0,6/0,8 m
	height: 2,20 m

Weights

Mechanical Balance of Plant	6,5 t
Electrical Balance of Plant	2,5 t
Fuel Cell Module	16 t

Sound Level at 1,0 m

Standard	81 dB(A)
Optional	66 dB(A)

FuelCell Energy Solutions GmbH is your partner for innovative CCHP-solutions with fuel cells in the extended European Area. For more information please visit our website at www.fc.es.de

Experiences and practical orientation

Innovative energy producers appreciate our long-term full-service.

Direct FuelCell® power plants are generating ultra-clean, efficient and reliable power at more than 65 locations worldwide. With over 180 megawatts of power generation capacity installed or in backlog, FuelCell Energy Solutions GmbH/ FuelCell Energy, Inc. is a global leader in providing ultra-clean baseload distributed generation to utilities, industrial operations, universities, municipal water treatment facilities, government installations and other customers around the world.

The Company's power plants have generated more than one billion kilowatt hours of ultra-clean power using a variety of fuels including renewable biogas from wastewater treatment and food processing, as well as natural gas.



university



biogas plant



sewage plant

The fleet of Direct FuelCell power plants of FuelCell Energy Solutions GmbH/ FuelCell Energy, Inc. are certified to or comply with a variety of commercial and industrial standards: ANSI/CSA America FC-1, UL 1741, CARB 2007, OSHA 29 CFR Part 1910, IEEE 1547, NFPA 70, NFPA 853, and California Rule 21.

This brochure provides a general overview of FuelCell Energy Solutions GmbH/ FuelCell Energy, Inc. products and services. This brochure is provided for informational purposes only. Warranties for FuelCell Energy Solutions GmbH/ FuelCell Energy, Inc. products and services are provided only by individual sales and service contracts, and not by this brochure. This brochure is not an offer to sell any FuelCell Energy Solutions GmbH/ FuelCell Energy, Inc. products and services. Contact FuelCell Energy Solutions GmbH for detailed product information suitable for your specific application. FuelCell Energy Solutions GmbH/ FuelCell Energy, Inc. reserves the right to modify its products, services, and related information at any time without prior notice.

FuelCell Energy with the corresponding logo is a registered trademark of FuelCell Energy, Inc. "Direct FuelCell," "DFC" and "DFC/T" are registered trademarks of FuelCell Energy, Inc. © FuelCell Energy, Inc. 2012. All rights reserved.



FuelCell Energy Solutions
Ultra-Clean, Efficient, Reliable Power

FuelCell Energy Solutions GmbH
Winterbergstr. 28
01277 Dresden, Germany
+49 351 25 53 73 90
info@fc.es.de
www.fc.es.de